



## Explanations for Exam #2



## EM Technical Advocacy Team

Cisco | Networking Academy®  
Mind Wide Open™



1. Refer to the exhibit. The exhibit shows simplified protocol data units from different OSI model layers. Which three statements are true about the PDUs and the encapsulation process? (Choose three.)

- A. PDU #1 is a frame.
- B. PDU #2 is an application layer PDU.
- C. PDU #3 is a segment.
- D. PDU #4 is a transport layer PDU.
- E. The order in which these PDUs are created during the encapsulation process is 3, 4, 1, 2.
- F. The order in which these PDUs are created during the encapsulation process is 2, 1, 4, 3.

PDU #1	Source BB-12-69- D1-14-06	Destination 00-00-C0- AA-65-21	Type 0x0800	DATA	FCS
PDU #2	110011001011001011001011100010101001010111011111				
PDU #3	Source Port 1079	Destination Port 80	Sequence 22811786	Acknowledgment 37689217	Window 17520 DATA
PDU #4	Source 192.168.200.1	Destination 172.17.24.8	Protocol 0x06	DATA	



## 2. Which three application layer protocols use TCP? (Choose three.)

- A. SMTP
- B. FTP.
- C. SNMP
- D. HTTP.
- E. TFTP.
- F. DHCP



### 3. Which two application layer protocols use the UDP protocol? (Choose two.)

- A. Telnet
- B. **SNMP**
- C. SMTP
- D. SQL
- E. **TFTP**



#### 4. What are two functions that occur at the Internet layer of the TCP/IP model? (Choose two.)

- A. Establishment of logical connections between source and destination hosts
- B. End-to-end flow control
- C. **Determination of best paths through the network**
- D. Definition of the procedures used to interface with the network hardware
- E. **Packet switching**
- F. Layer 5 and Layer 6 OSI model functions



5. Refer to the exhibit. All ports on switch A are in the sales VLAN and all ports on switch B are in the accounting VLAN. How many broadcast domains and how many collision domains exist in the exhibited network? (Choose two.)

- A. 3 collision domains
- B. 3 broadcast domains
- C. 5 broadcast domains
- D. 9 collision domains
- E. 10 collision domains
- F. 13 collision domains

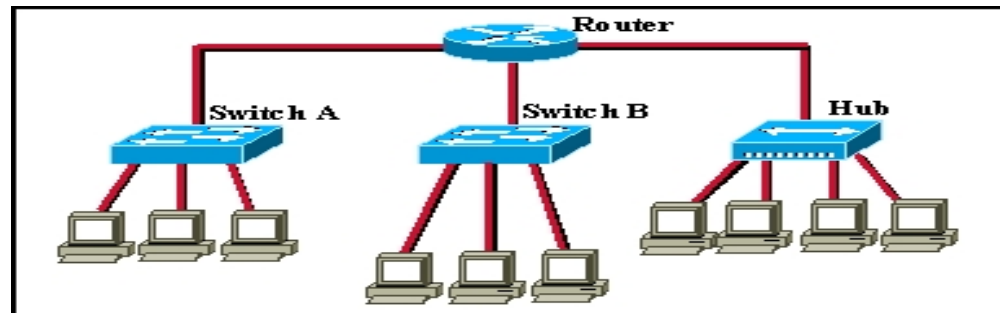



6. A high-end Catalyst switch that supports both ISL and 802.1Q is to be connected by a link that will carry all VLAN traffic to a Catalyst 2960 LAN switch. What two commands are required to configure an interface on the high-end Catalyst switch to carry traffic from all VLANs to the Catalyst 2960 switch? (Choose two.)

- A. Switch(config-if)# vlan all
- B. Switch(config-if)# switchport access vlan 30
- C. Switch(config-if)# switchport access vlan all
- D. Switch(config-if)# switchport mode trunk
- E. Switch(config-if)# switchport trunk encapsulation dot1q
- F. Switch(config-if)# switchport trunk encapsulation isl



## 7. Refer to the exhibit. Based on the exhibited configuration and output, what would be the result of this command?

Sw1# telnet 192.168.1.10

- A. All packets will be dropped.
- B. The Telnet session will succeed.
- C. An error message that says “Session terminated” will appear.
- D. An error message that says “Password required, but none set” will appear.

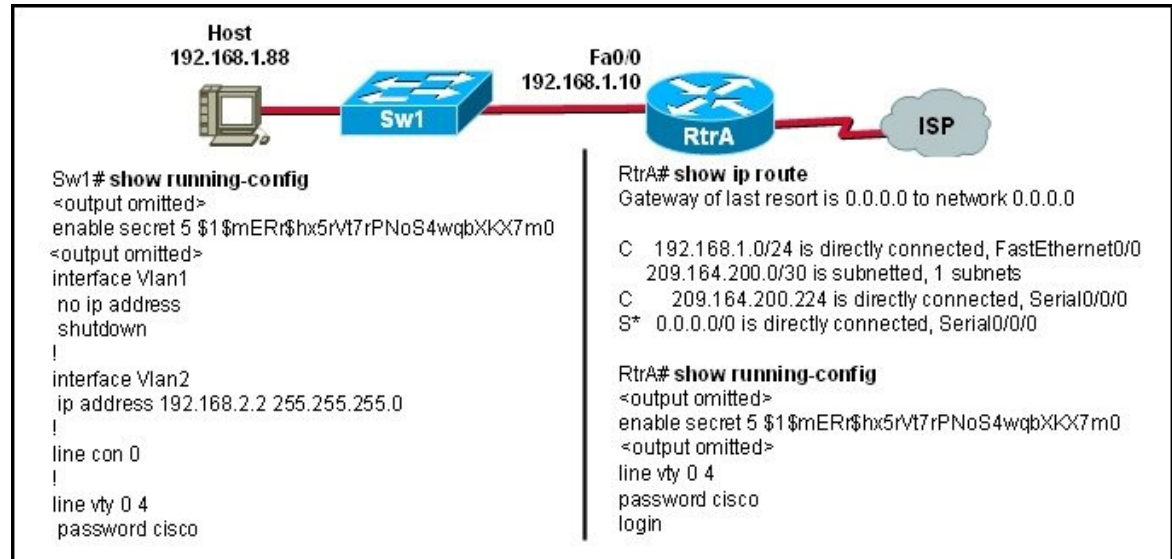





## 8. Refer to the partial device configuration that is exhibited. For which network topology is the configuration appropriate?

```

RtrA(config)# interface fastethernet 0/0
RtrA(config-if)# no shutdown
RtrA(config-if)# interface fastethernet 0/0.18
RtrA(config-subif)# encapsulation dot1q 18
RtrA(config-subif)# ip address 10.1.18.1 255.255.255.0
RtrA(config-subif)# interface fastethernet 0/0.44
RtrA(config-subif)# encapsulation dot1q 44
RtrA(config-subif)# ip address 10.1.44.1 255.255.255.0
RtrA(config-subif)# interface fastethernet 0/0.22
RtrA(config-subif)# encapsulation dot1q 22
RtrA(config-subif)# ip address 10.1.22.1 255.255.255.0
    
```

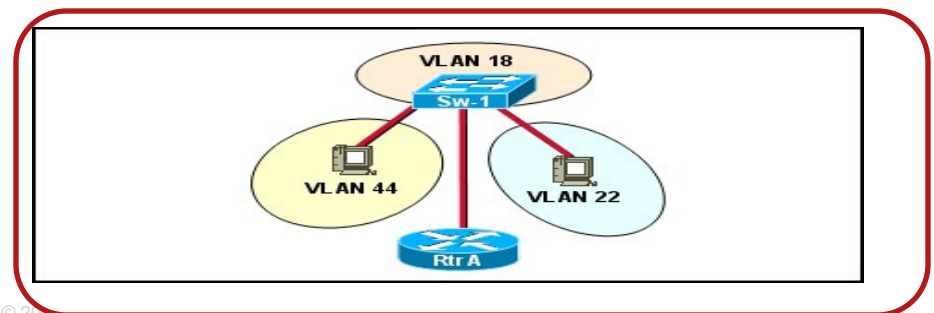
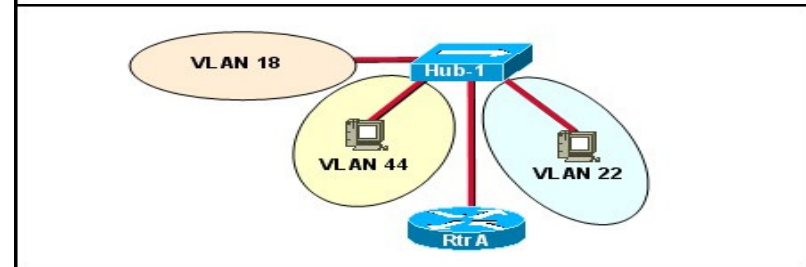
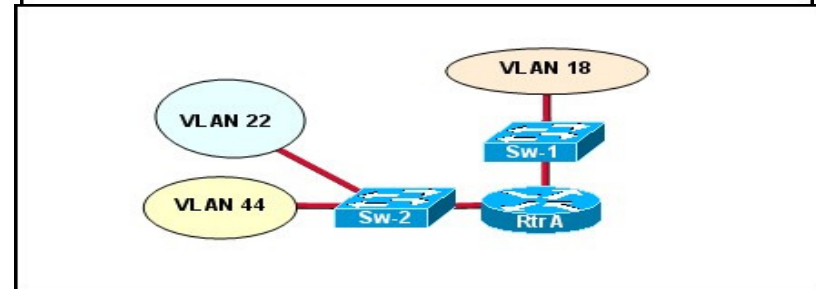
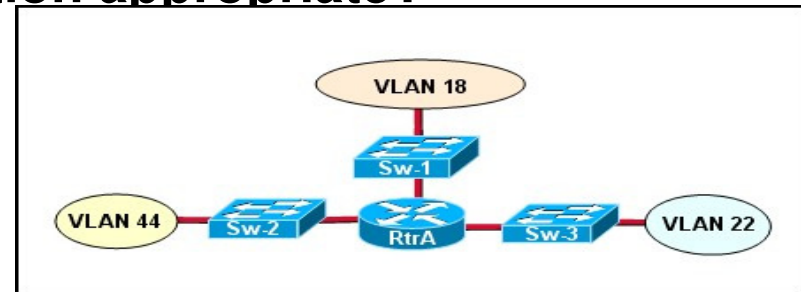



**10. A network administrator is configuring a switch when an error message appears. The configuration commands and error message appear as follows:**

```
Switch(config)# interface fastethernet 0/1
```

```
Switch(config-if)# switchport mode trunk
```

***Command rejected: An interface whose trunk encapsulation is "Auto" can not be configured to "trunk" mode.***

- A. The switch port is configured as an access mode port.
- B. The switch port does not support trunking on this port.
- C. **The encapsulation type must be changed to a compatible protocol before the port can be placed in trunk mode.**
- D. The no switchport trunk encapsulation auto command needs to be applied to the to the switch port before trunking can be enabled.



**11. Of the protocols that are listed, which one needs to be functioning on a link in order for VTP to operate?**

- A. 802.1Q
- B. CDP
- C. RIP
- D. RSTP



## 12. Refer to the exhibit. RT\_1 is configured correctly with IP addresses and passwords but none of the computers can ping or telnet to RT\_1. Which series of commands would correct the problem?

- A. RT\_1(config)# interface fa0/1  
RT\_1(config-if)# no shutdown
- B. SW\_1(config)# interface fa0/24  
SW\_1(config-if)# switchport mode client
- C. RT\_1(config)# interface fa0/1  
RT\_1(config-if)# encapsulation trunk dot1q 24
- D. **SW\_1(config)# interface fa0/24**  
**SW\_1(config-if)# switchport mode trunk**
- E. SW\_1(config)# interface fa0/24  
SW\_1(config-if)# switchport access vlan 1

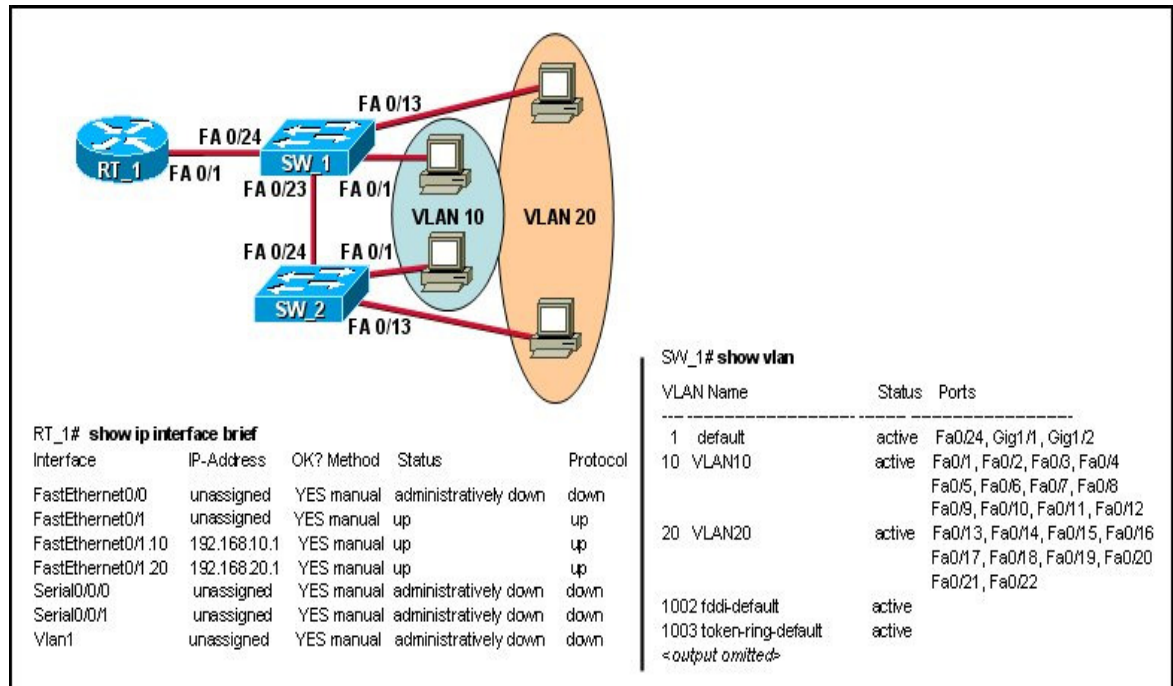



**13.** Refer to the exhibit. Which commands are needed to complete the switch configuration so that SSH can be used to telnet from host A to SW\_1? (Choose two.)

- A. `SW_1(config)# username david password class`
- B. `SW_1(config)# line vty 0 15`  
`SW_1(config-line)# login`  
`SW_1(config-line)# password cisco`
- C. `SW_1(config)# line vty 0 15`  
`SW_1(config-line)# login local`  
`SW_1(config-line)# transport input ssh`
- D. `SW_1(config)# login ssh`  
`SW_1(config)# password class`
- E. `SW_1(config)# login key rsa`  
`SW_1(config)# password cisco`
- F. `SW_1(config)# password encrypted cisco`





15. Refer to the exhibit. What protocol should be configured on SW-A Port 0/1 if it is to send traffic from multiple VLANs to switch SW-B?

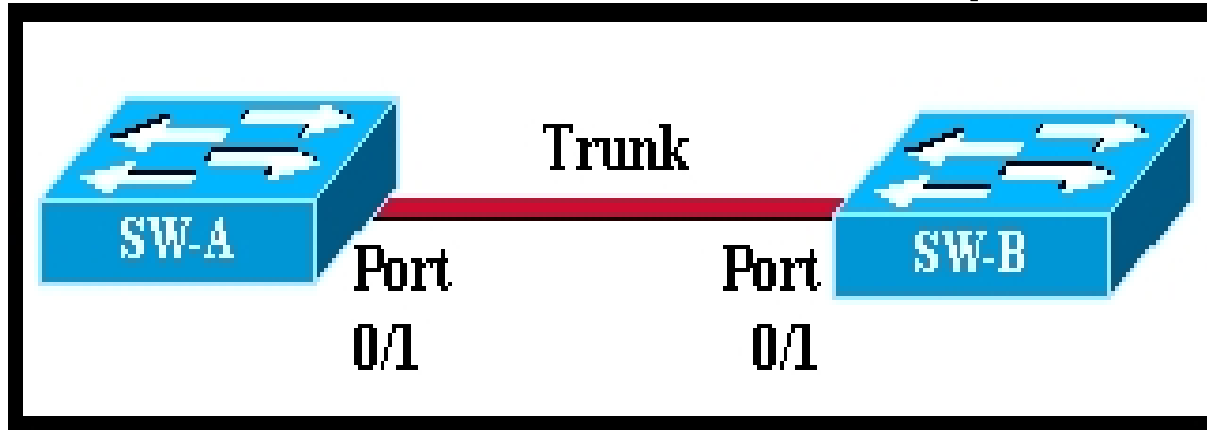

- A. Spanning Tree
- B. RIP v2
- C. IEEE 802.1Q
- D. ARP
- E. Rapid Spanning Tree



## 16. Which three STP states were replaced with the RSTP discarding state? (Choose three.)

- A. Listening
- B. Learning
- C. Blocking
- D. Disabled
- E. Forwarding



## 17. Refer to the exhibit. What is the role of the SW3 switch?

- A. Designated Switch
- B. Edge Switch
- C. **Root Bridge**
- D. Enabled Bridge
- E. Local Bridge

```
SW3# show spanning-tree

VLAN0001
Spanning tree enabled protocol ieee
Root ID Priority 32769
   Address 0001.427E.8D42
   This bridge is the root
   Hello Time 2 sec Max Age 20 sec Forward Delay 15 sec
Bridge ID Priority 32769 (priority 32768 sys-id-ext 1)
   Address 0001.427E.8D42
   Aging Time 300

Interface Role Sts Cost Prio.Nbr Type
-----
Fa1/2    Desg FWD 4  128.3 Shr
Fa1/1    Desg FWD 4  128.3 Shr
```





**18. Refer to the exhibit. A switch can be configured for three different forwarding modes based on how much of a frame is received before the forwarding process begins. Each of the numbered arrows in the accompanying graphic signifies the point in a frame where a particular forwarding mode will begin. Which group of labels reflects the sequence of forwarding modes signified by the numbered arrows?**

- A. 1) fast forward  
2) fragment free  
3) store-and-forward
- B. 1) store-and-forward  
2) fragment free  
3) fast forward
- C. 1) fragment free  
2) fast forward  
3) store-and-forward
- D. 1) fast forward  
2) store-and-forward  
3) fragment free

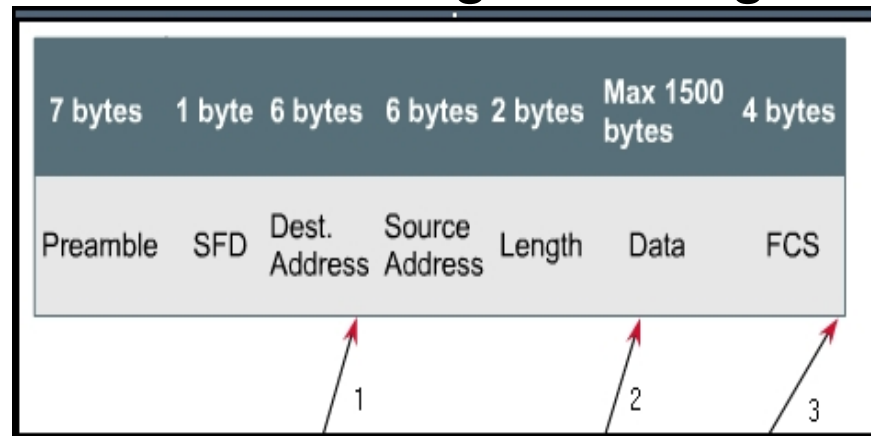



# 19. What eliminates switching loops?

- A. hold-down timers
- B. poison reverse
- C. **spanning tree protocol**
- D. time to live
- E. VTP



# Q20 Sim



21. Refer to the exhibit. Using the most efficient IP addressing scheme and VLSM, which address can be configured on one of the serial interfaces?

- A. 192.168.16.63/27
- B. 192.168.16.158/27
- C. 192.168.16.192/27
- D. 192.168.16.113/30
- E. 192.168.16.145/30
- F. **192.168.16.193/30**

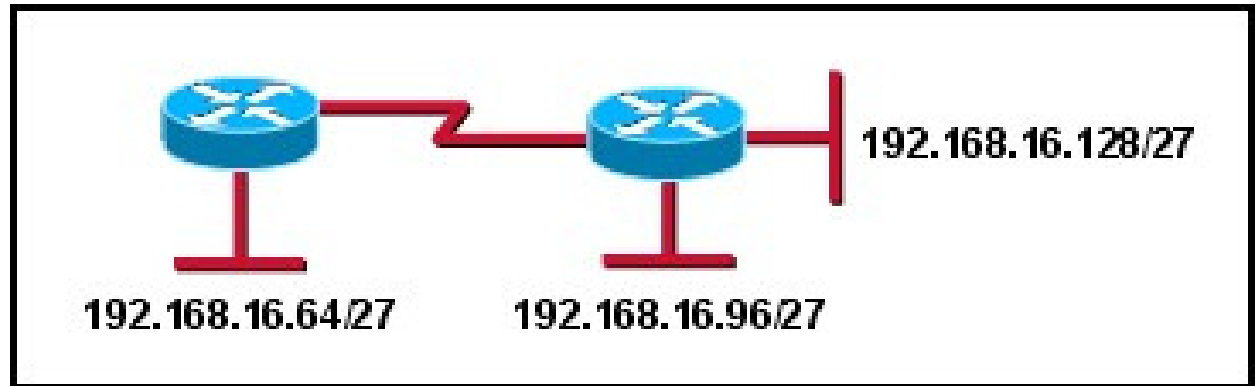



22. Consider this router output:

```
Router# confug
```

```
Translating "confug"...domain server (255.255.255.255)
```

```
Translating "confug"...domain server (255.255.255.255)
```

```
(255.255.255.255)% Unknown command or computer name, or unable to find computer address
```

What command could help with this situation?

- A. ip dhcp server
- B. **no ip domain-lookup**
- C. no logging synchronous
- D. no show ip nat translations



23. Refer to the exhibit. With VLSM, which bit mask should be used to most efficiently provide for the number of host addresses that are required on router B?

- A. /26
- B. /27
- C. /28
- D. /29
- E. /30

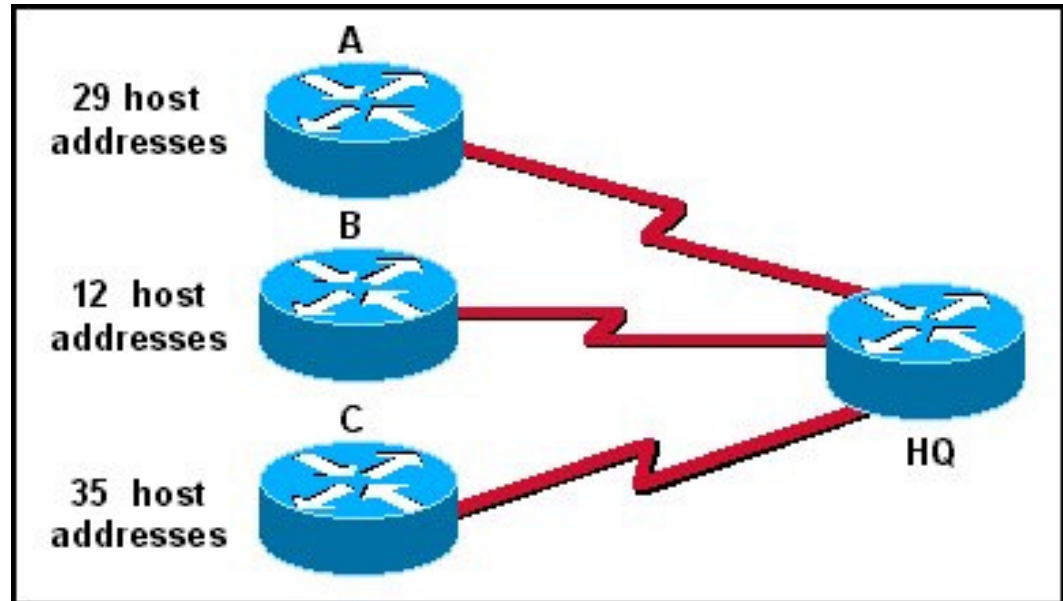



## 24. What are the three ranges of IP addresses that are reserved for internal private use? (Choose three.)

- A. 10.0.0.0/8
- B. 64.100.0.0/14
- C. 127.16.0.0/12
- D. 172.16.0.0/12
- E. 192.31.7.0/24
- F. 192.168.0.0/16



25. Refer to the exhibit. The network administrator is unable to access the TFTP server attached to the Memphis router. What are two causes of this problem? (Choose two.)

- A. The default gateway configured on the network administrator's workstation is not a valid host address.
- B. The default gateway configured on the TFTP server is incorrect.
- C. The IP address of the TFTP server is a subnetwork address.
- D. The IP address of the S0/0/0 interface of the Heliopolis router is a broadcast address.
- E. The IP addresses for the Memphis S0/0/1 interface and the Heliopolis S0/0/0 interface are not in the same subnet.

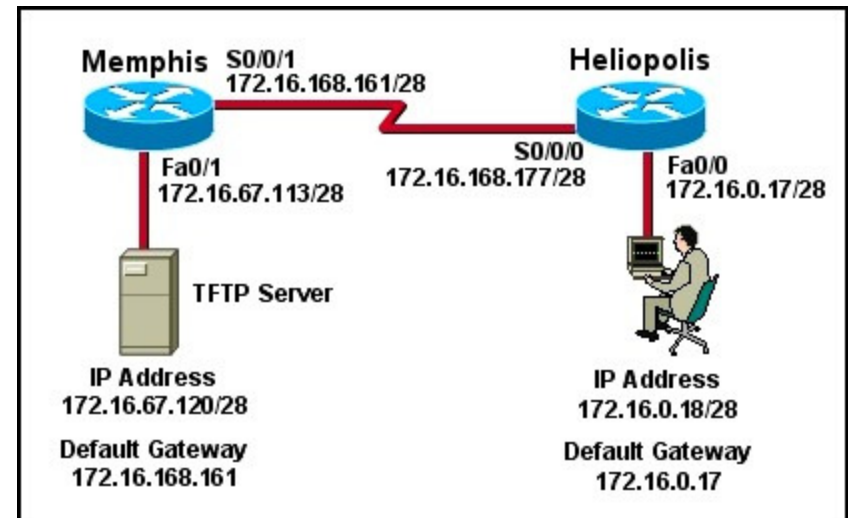





**26. The ISP of the XYZ Company is moving to IPv6 but XYZ wants to continue to use only IPv4 for another year. Which IPv4-to-IPv6 transition method would allow the company to continue using only IPv4 addresses?**

- A. dual stack
- B. 6to4 tunnel
- C. manual tunneling
- D. **NAT-PT**



27. Given the IP address and subnet mask of 172.16.134.56  
255.255.255.224, on which subnetwork does this address reside?

- A. 172.16.0.0
- B. 172.16.134.0
- C. **172.16.134.32**
- D. 172.16.134.48
- E. 172.16.134.47
- F. 172.16.134.63



## 28. What is associated with link-state routing protocols?

- A. low processor overhead
- B. poison reverse
- C. routing loops
- D. split horizon
- E. **shortest-path first calculations**



## 29. Refer to the exhibit. Which sequence of commands should be used to configure router A for OSPF?

- A. router ospf 1  
network 192.168.10.0
- B. router ospf 1  
network 192.168.10.64 0.0.0.63 area 0  
network 192.168.10.192 0.0.0.3 area 0
- C. router ospf 1  
network 192.168.10.64 255.255.255.192  
network 192.168.10.192 255.255.255.252
- D. router ospf 1  
network 192.168.10.0 area 0

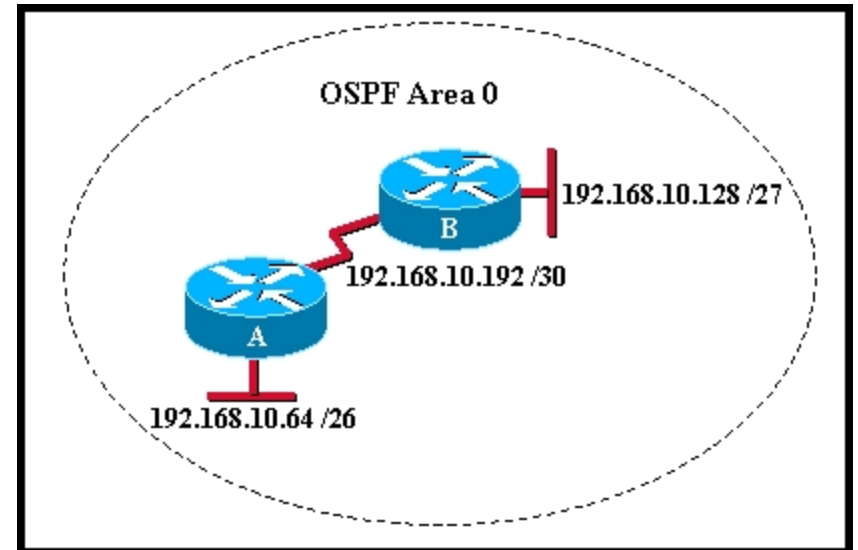



## 30. What is one reason to use the `ip ospf priority` command when the OSPF routing protocol is in use?

- A. to activate the OSPF neighboring process
- B. **to influence the DR/BDR election process**
- C. to provide a backdoor for connectivity during the convergence process
- D. to streamline and speed up the convergence process



**31. The output of the show ip interface brief command indicates that Serial0 is up but the line protocol is down. What are two possible causes for the line protocol being in the down state? (Choose two.)**

- A. The clock rate is not set on the DTE.
- B. An incorrect default gateway is set on the router.
- C. A network is missing from the routing protocol configuration.
- D. **The encapsulation on the Serial0 interface is incorrect.**
- E. **Keepalives are not being sent by the remote device.**



## 32 Which router command will verify that the router has a path to a destination network?

- A. Router# **show ip interfaces brief**
- B. Router# **show ip route**
- C. Router# **show cdp neighbors**
- D. Router# **show running-config**
- E. Router# **show protocols**



33. Refer to the exhibit. When troubleshooting a network, it is important to interpret the output of various router commands. On the basis of the exhibit, which three statements are true? (Choose three.)

- A. The missing information for Blank 1 is the command show ip route.
- B. The missing information for Blank 1 is the command debug ip route.
- C. The missing information for Blank 2 is the number 100.
- D. The missing information for Blank 2 is the number 120.
- E. The missing information for Blank 3 is the letter R.
- F. The missing information for Blank 3 is the letter C.

```

Router # [redacted] ← 1
Codes: C - connected, S - static, I - IGRP, R - RIP, M - mobile,
       B - BGP D - EIGRP, EX - EIGRP external, O - OSPF
<output text omitted>
Gateway of last resort is not set
R 172.30.0.0/16 [redacted]/3] via 200.100.100.2, 00:00:14, Serial0
3 → [redacted] 10.5.5.0/24 is directly connected, Ethernet0
    
```





34. Refer to the exhibit. From the command prompt on the host, the command telnet 192.168.1.10 is typed. The response that is given is this:  
 Trying 192.168.1.10....Open  
 Password required, but none set  
 What is the most likely problem?

- A. The router has been configured as a firewall.
- B. The Telnet server process must be activated on the router.
- C. The switch has not been configured to pass Telnet traffic.
- D. The enable secret command has not been entered on RtrA.
- E. The password command has not been entered in line configuration mode on RtrA.
- F. The password and login commands need to be configured on the console configuration of RtrA.

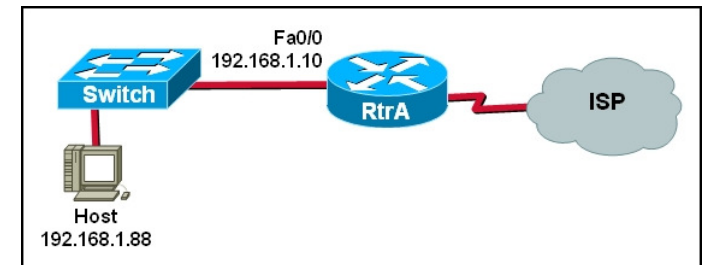



## 35. Refer to the exhibit. If router B is to be configured for EIGRP AS 100, which configuration must be entered?

- A. B(config-router)# network 192.168.10.4 0.0.0.3  
B(config-router)# network 192.168.10.8 0.0.0.3
- B. B(config-router)# network 192.168.10.4 0.0.0.3  
B(config-router)# network 192.168.10.8 0.0.0.3  
B(config-router)# network 192.168.10.128 0.0.0.63
- C. B(config-router)# network 192.168.10.4 0.0.0.3 area 0  
B(config-router)# network 192.168.10.8 0.0.0.3 area 0  
B(config-router)# network 192.168.10.128 0.0.0.63 area 0
- D. B(config-router)# network 192.168.10.4 0.0.0.3 as 100  
B(config-router)# network 192.168.10.8 0.0.0.3 as 100  
B(config-router)# network 192.168.10.128 0.0.0.63 as 100
- E. B(config-router)# network 192.168.10.4 0.0.0.3  
B(config-router)# network 192.168.10.8 0.0.0.3  
B(config-router)# network 192.168.10.64 0.0.0.63  
B(config-router)# network 192.168.10.128 0.0.0.63  
B(config-router)# network 192.168.10.192 0.0.0.63
- F. B(config-router)# network 192.168.10.4 0.0.0.3 as 100  
B(config-router)# network 192.168.10.8 0.0.0.3 as 100  
B(config-router)# network 192.168.10.64 0.0.0.63 as 100  
B(config-router)# network 192.168.10.128 0.0.0.63 as 100  
B(config-router)# network 192.168.10.192 0.0.0.63 as 100
- G. B(config-router)# network 192.168.10.4 0.0.0.3 area 100  
B(config-router)# network 192.168.10.8 0.0.0.3 area 100  
B(config-router)# network 192.168.10.64 0.0.0.63 area 100  
B(config-router)# network 192.168.10.128 0.0.0.63 area 100  
B(config-router)# network 192.168.10.192 0.0.0.63 area 100

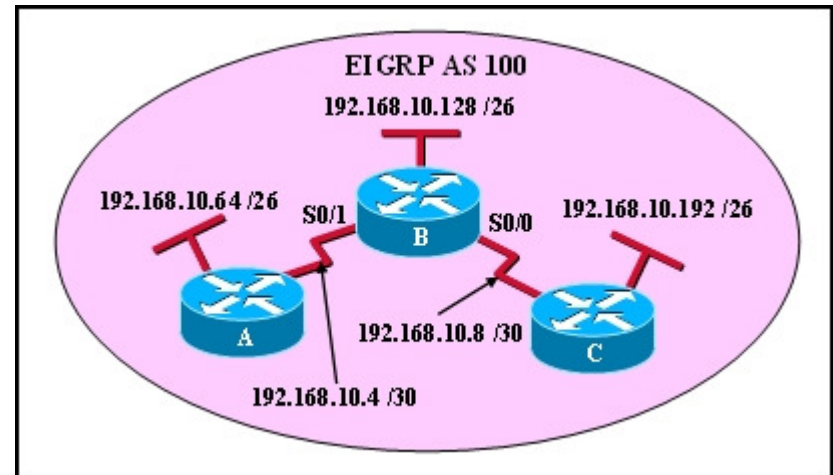



**36. After several configuration changes are made to a router, the copy running-configuration startup-configuration command is issued. Where will the changes be stored?**

- A. flash
- B. ROM
- C. **NVRAM**
- D. RAM
- E. the configuration register
- F. a TFTP server



37. Refer to the exhibit. Two routers have been configured to use EIGRP. Packets are not being forwarded between the two routers. What could be the problem?

- A. EIGRP does not support VLSM.
- B. The routers were not configured to monitor neighbor adjacency changes.
- C. The default bandwidth was used on the routers.
- D. **An incorrect IP address was configured on a router interface.**

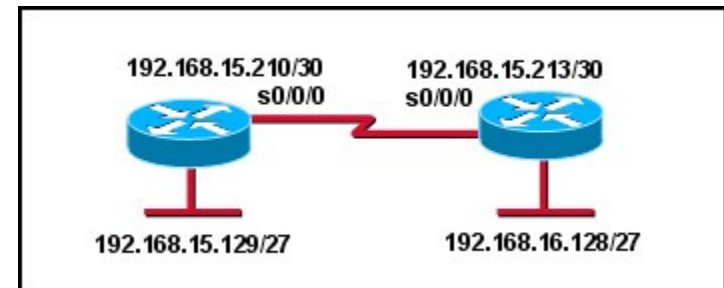



## 38. What are two features of a link-state routing protocol? (Choose two.)

- A. Routers send periodic updates only to neighboring routers.
- B. Routers send triggered updates in response to a change.
- C. Routers create a topology of the network by using information from other routers.
- D. The database information for each router is obtained from the same source.
- E. Paths are chosen based on the lowest number of hops to the designated router.



39. Refer to the exhibit. Routers A and B have EIGRP configured and automatic summarization has been disabled on both routers. Which router command is used to summarize the attached routes, and to which interface is this command applied? (Choose two.)

- A. `ip summary-address eigrp 1 192.168.10.64 255.255.255.192`
- B. `ip area-range eigrp 1 192.168.10.80 255.255.255.224`
- C. `summary-address 192.168.10.80 0.0.0.31`
- D. `ip summary-address eigrp 1 192.168.10.64 0.0.0.63`
- E. **serial interface on router A**
- F. serial interface on router B

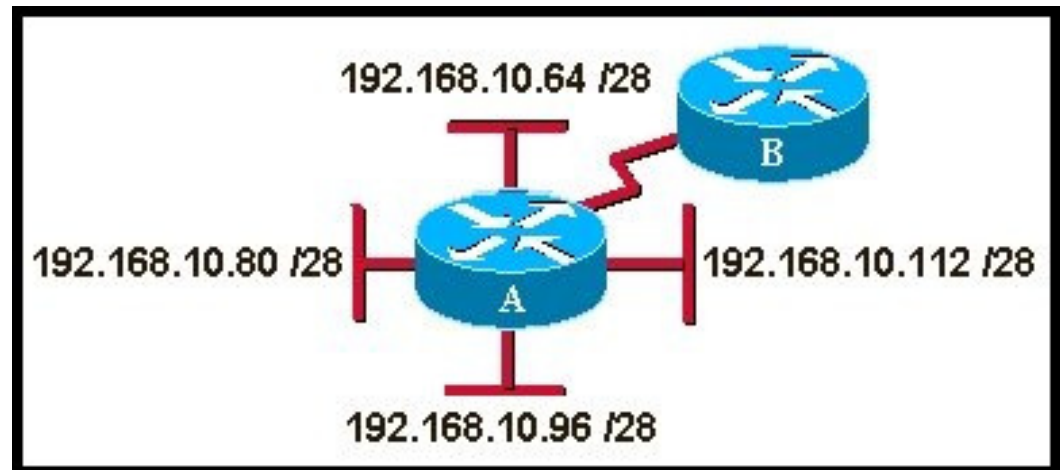



## 41. Which sequence of commands is used to configure a loopback address on a router?

- A. Router1(config)# **interface loopback 1**  
Router1(config-if)# **ip address 192.168.1.1**
- B. Router1(config)# **interface serial 0/0**  
Router1(config-if)# **loopback 1**  
Router1(config-if)# **ip address 192.168.1.1**
- C. Router1(config)# **interface serial 0/0**  
Router1(config-if)# **loopback 1**  
Router1(config-if)# **ip address 192.168.1.1 255.255.255.0**
- D. **Router1(config)# interface loopback 1**  
**Router1(config-if)# ip address 192.168.1.1 255.255.255.255**

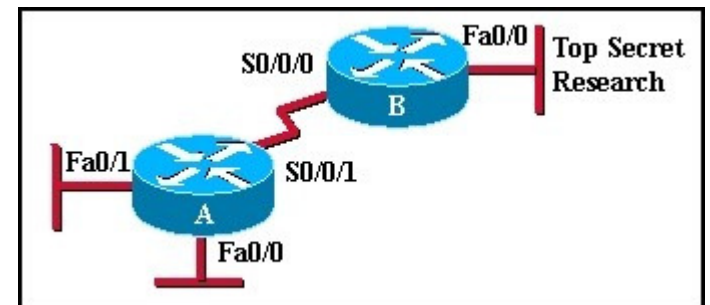



# 42 Sim





# 45.

This is a flash item. Please click below to answer this item.

Drag the security threat on the left to the mitigation method on the right. (Not all options are used.)

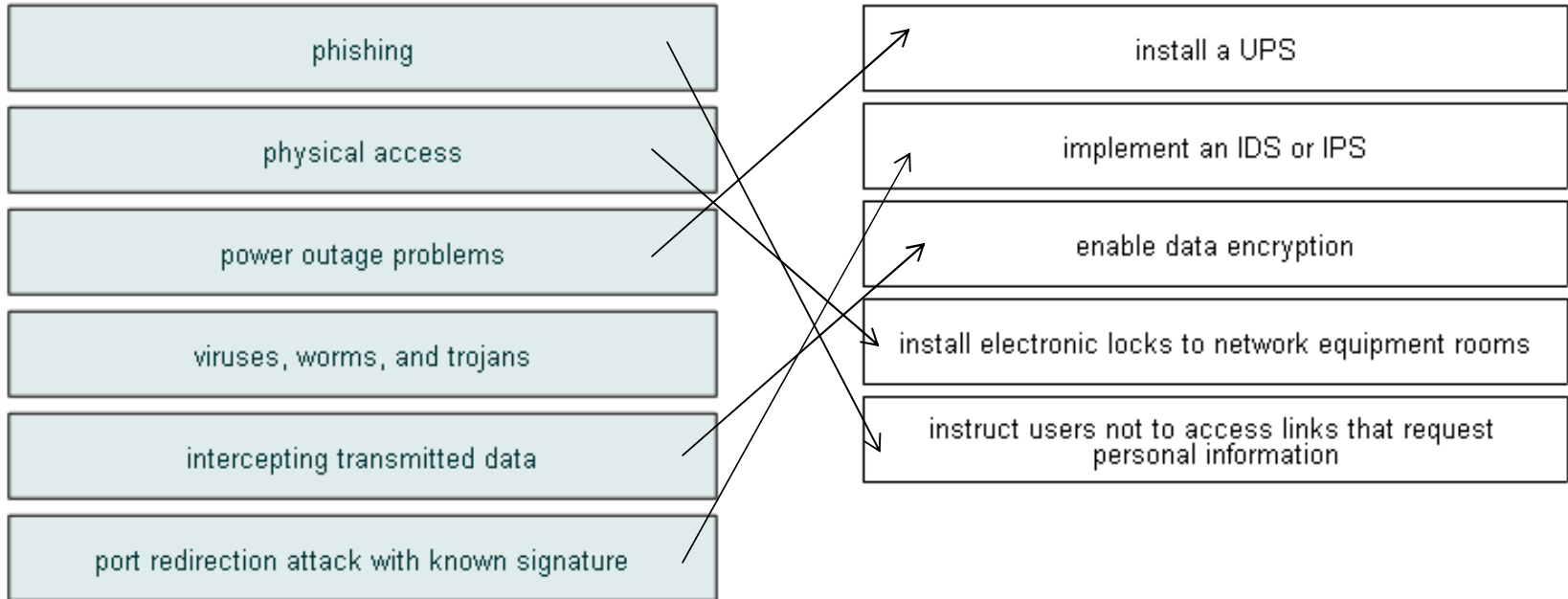



46. Which two commands can be used to verify the content and placement of access control lists? (Choose two.)

- A. show ip route
- B. show processes
- C. **show running-config**
- D. show cdp neighbor
- E. **show access-lists**



48. Refer to the exhibit. NAT with overload is configured on router R1 and uses the NAT pool of addresses 209.165.201.9 through 209.165.201.10. What type of route would the ISP need in order for communication to occur between hosts in Company ABC and the Internet?

- A. Because the ISP has knowledge of the directly connected 200.0.0.1 network, no route is needed.
- B. A static route from the ISP is needed that uses the network number 172.16.0.0 and the mask 255.255.0.0.
- C. A default route from the ISP is needed that uses either the exit interface of S0/0/0 or the 200.0.0.1 IP address.
- D. A default route from the ISP is needed that uses either the exit interface of S0/0/1 or the 200.0.0.2 IP address.
- E. **A static route from the ISP is needed that uses the network number 209.165.201.8 and the mask 255.255.255.252.**

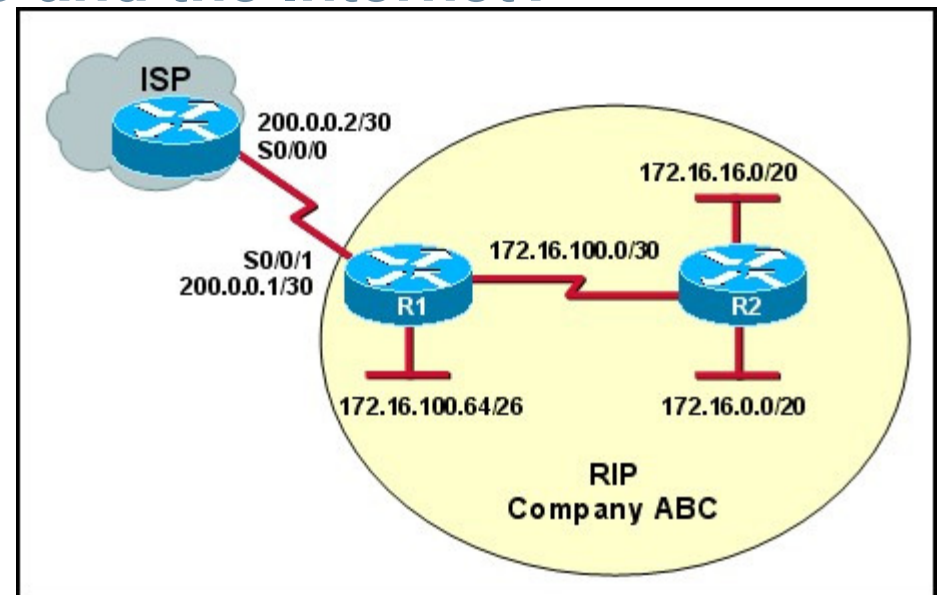



## 49. What is the effect of the access control list wildcard mask 0.0.0.15? (Choose two.)

- A. The first 28 bits of a supplied IP address will be ignored.
- B. **The last four bits of a supplied IP address will be ignored.**
- C. The first 32 bits of a supplied IP address will be matched.
- D. **The first 28 bits of a supplied IP address will be matched.**
- E. The last five bits of a supplied IP address will be ignored.
- F. The last four bits of a supplied IP address will be matched.



50. Which three values or sets of values are included when creating an extended access control list statement? (Choose three.)

- A. access list number between 1 and 99
- B. access list number between 100 and 199
- C. default gateway address and wildcard mask
- D. destination address and wildcard mask
- E. source address and wildcard mask
- F. source subnet mask and wildcard mask
- G. destination subnet mask and wildcard mask



# 51. Refer to the exhibit. Which statement describes the status of the PPP connection?

```

Serial1 is up, line protocol is up
Hardware is HD64570
Internet address is 200.200.200.1/24
MTU 1500 bytes, BW 1544 Kbit, DLY 20000 usec,
  reliability 255/255, txload 1/255, rxload 1/255
Encapsulation PPP, loopback not set
Keepalive set (10 sec)
LCP Open
Open: IPCP, CDPCP
Last input 00:00:04, output 00:00:04, output hang never
Last clearing of "show interface" counters 00:08:59
Input queue: 0/75/0/0 (size/max/drops/flushes); Total output drops: 0
Queueing strategy: weighted fair
Output queue: 0/1000/64/0 (size/max total/threshold/drops)
  Conversations 0/1/256 (active/max active/max total)
  Reserved Conversations 0/0 (allocated/max allocated)
  Available Bandwidth 1158 kilobits/sec
  
```

- A. Only the link-establishment phase completed successfully.
- B. Only the network-layer phase completed successfully.
- C. Neither the link-establishment phase nor the network-layer phase completed successfully.
- D. **Both the link-establishment and network-layer phase completed successfully.**



## 52. Which three statements are true regarding the Frame Relay LMI? (Choose three.)

- A. The LMI provides a virtual circuit (VC) status mechanism.
- B. The LMI type must always be manually configured.
- C. The available LMI types are CHAP and PAP.
- D. The LMI types supported by Cisco routers are CISCO and IETF.
- E. The LMI type configured on the router must match the one used on the Frame Relay switch.
- F. The LMI uses reserved DLCIs to exchange messages between the DTE and DCE.



**53. A network administrator is evaluating authentication protocols for a PPP link. Which three factors might lead to the selection of CHAP over PAP as the authentication protocol? (Choose three.)**

- A. establishes identities with a two-way handshake
- B. uses a three-way authentication periodically during the session to reconfirm identities
- C. control by the remote host of the frequency and timing of login events
- D. transmits login information in encrypted format
- E. uses an unpredictable variable challenge value to prevent playback attacks
- F. makes authorized network administrator intervention a requirement to establish each session





## 54. Which three statements are true about PPP? (Choose three.)

- A. PPP can use synchronous and asynchronous circuits.
- B. PPP can only be used between two Cisco devices.
- C. PPP carries packets from several network layer protocols in LCPs.
- D. PPP uses LCPs to establish, configure, and test the data link connection.
- E. PPP uses LCPs to agree on format options such as authentication, compression, and error detection.

# Cisco | Networking Academy<sup>®</sup>

Mind Wide Open<sup>™</sup>